

2

1

B

B

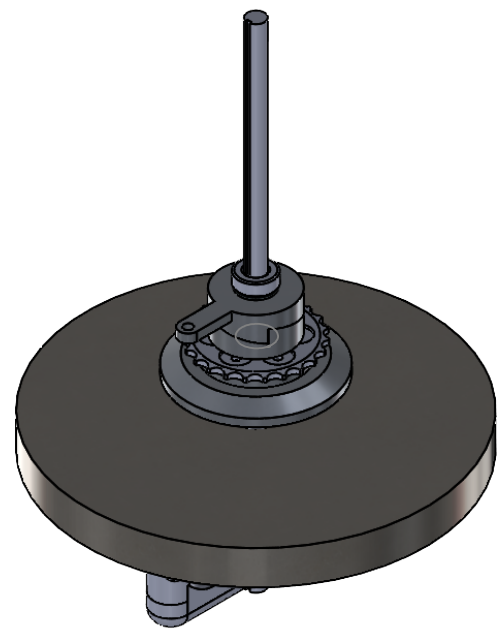
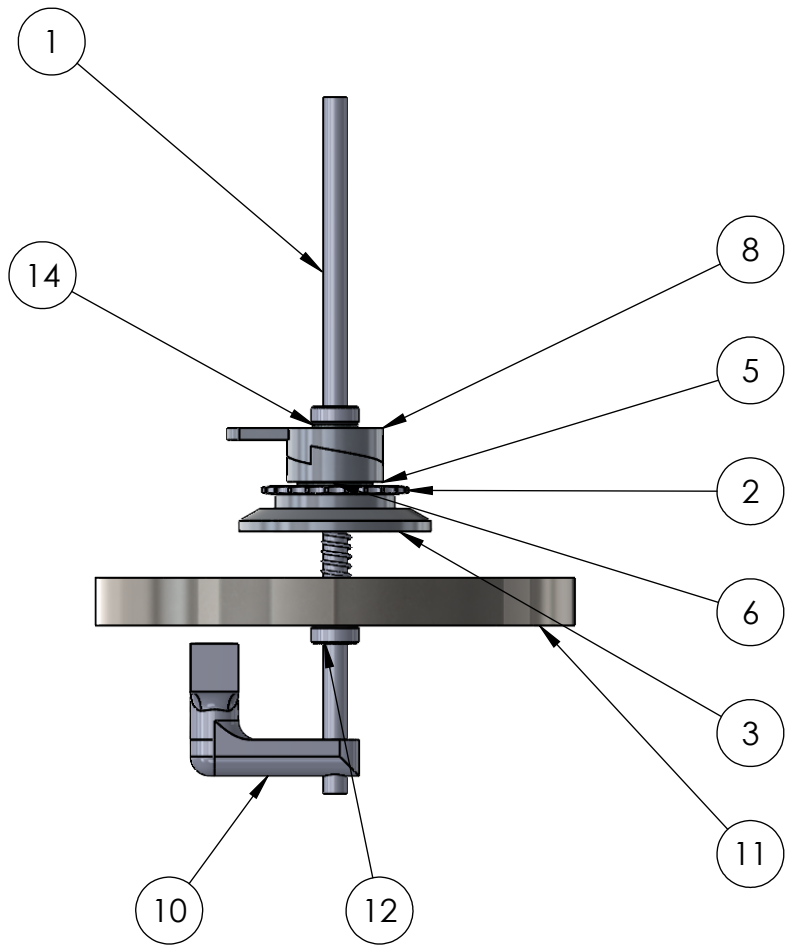

A

A

	NAME	DATE	TITLE:	
DRAWN	HPVCP	12/8/21	PROPULSION SYS. ASSEMBLY	
ADVISOR'S APPROVAL			SIZE	DWG. NO.
COMMENTS:			REV	
			A Propusion sys. ASM.	
SCALE: 1:4		WEIGHT:	SHEET 1 OF 2	

MATERIAL

2

1

B

B

A

A

ITEM NO.	PART NUMBER	DESCRIPTION	QTY.
1	ME486C inner shaft 1	D0.5" X L14.5"	1
2	ME486 sprocket 1	D2.8" X W0.15"	1
3	ME486 FRICTION PLATE FIXTURE 1	D4" X W0.87"	1
4	ME486C carrier bearing1	D1.08" X W0.31"	2
5	ME486 TOP JAW	D2" X W0.75"	1
6	needle bearing	D1.56" X W0.1"	1
7	retaining clip	R0.57" X W0.04"	1
8	ME486 BOTTOM JAW	3" X 2" X 0.75"	1
9	ME486C flywheel bearing1	D1.33" X W0.44"	2
10	ME 486 Hall effect sensor mount	4" X 2.75" X 1.5"	1
11	ME486 FLYWHEEL 1	D12" X W1"	1
12	collar	D1" X W0.38"	2
13	ME 486 spring	D0.06"	1
14	grainger-4xfn2	D1" X W0.1"	1

MATERIAL

	NAME	DATE	TITLE: BILL OF MATERIALS	
DRAWN	HPVCP	12/8/21		
ADVISOR'S APPROVAL			SIZE	
COMMENTS:				
			REV	
			ABOM of Propulsion sys.	
			WEIGHT:	
			SHEET 2 OF 2	